

MIP MOT FLEX ZERO

Motorized wall mount

Soporte suelo-pared motorizado

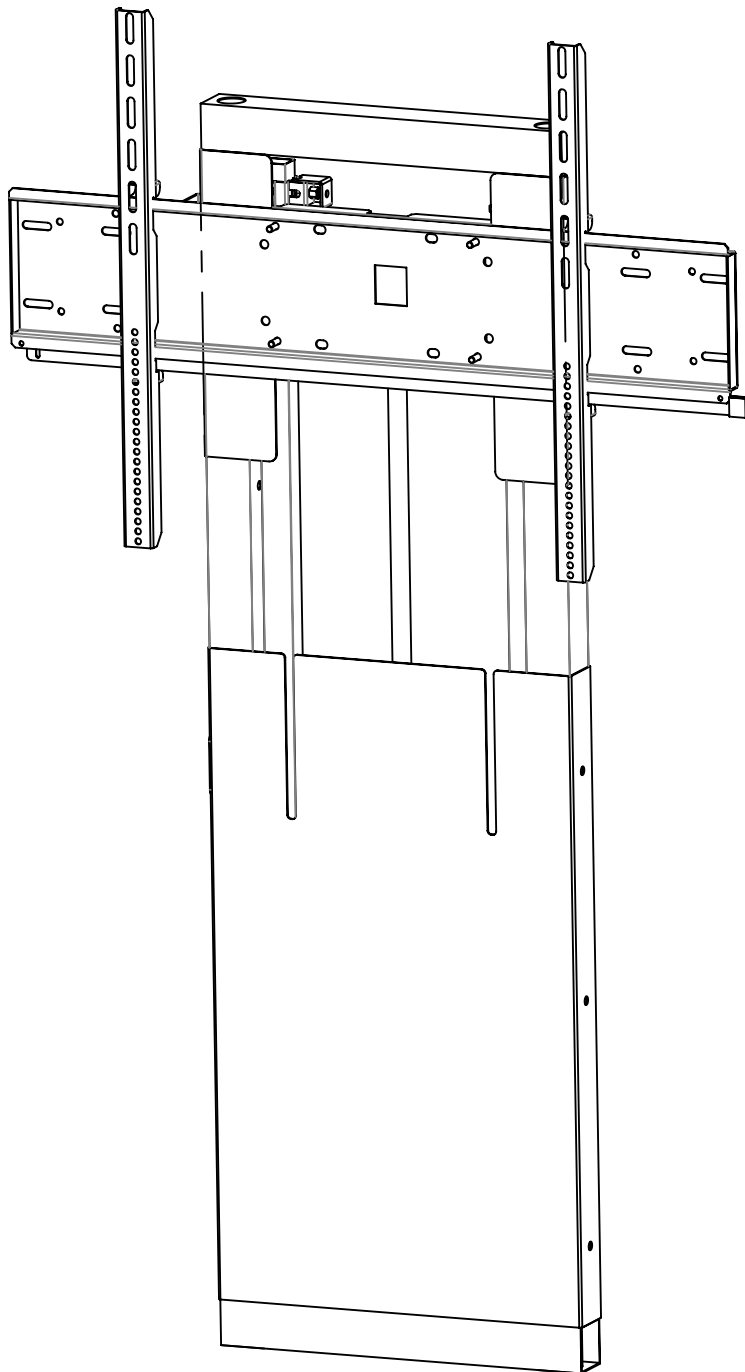

Installation manual

Manual de instalación

Manuale di installazione

Asennusopas

Manuel d'installation.

DIMASA

Education, Corporate & Rental Mounts

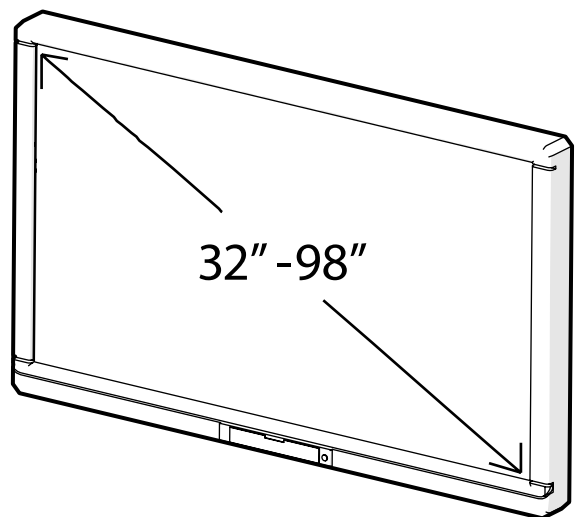
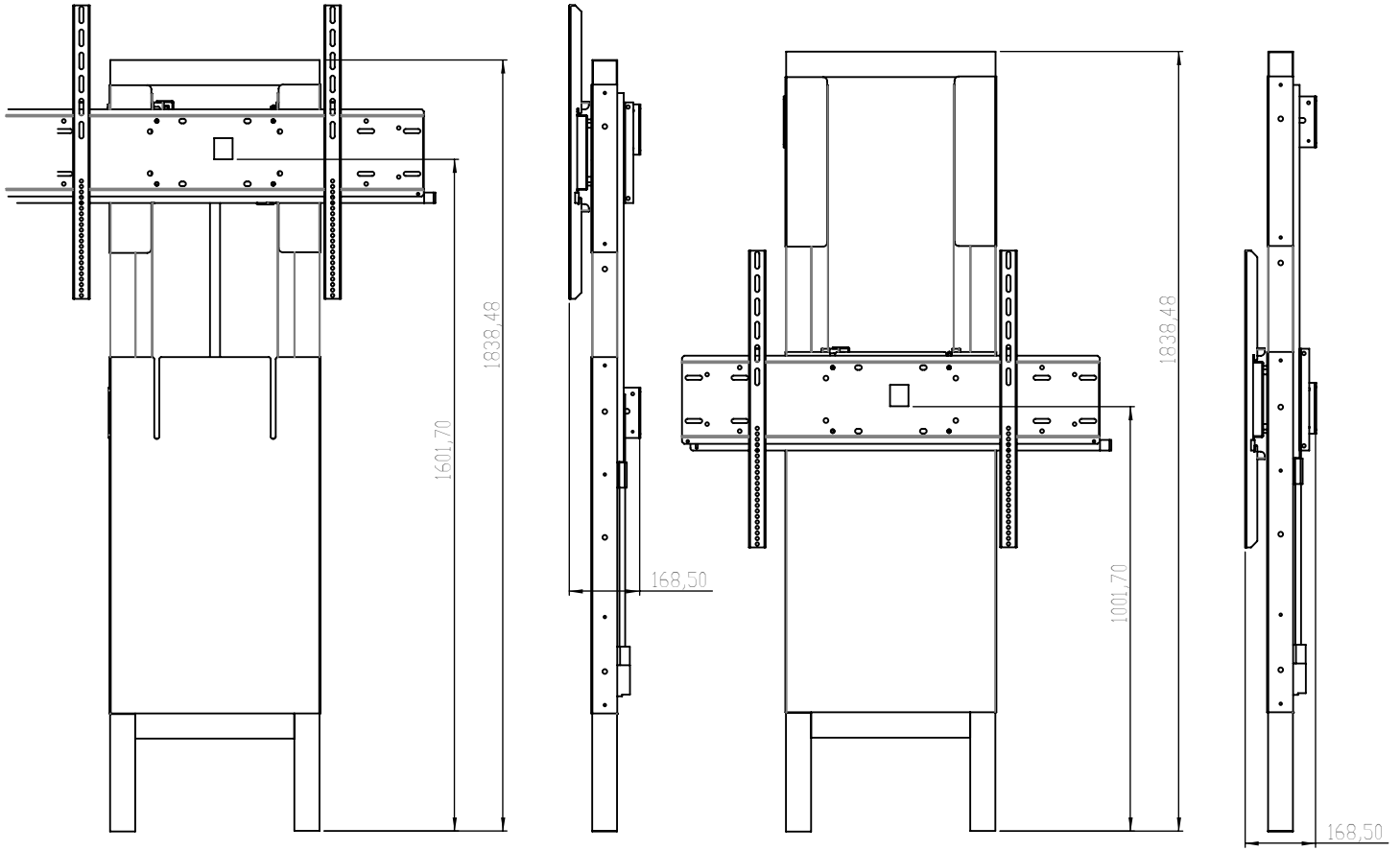

CONTENIDO/CONTENTS/CONTENUTO/SISÄLLYS/CONTENU:

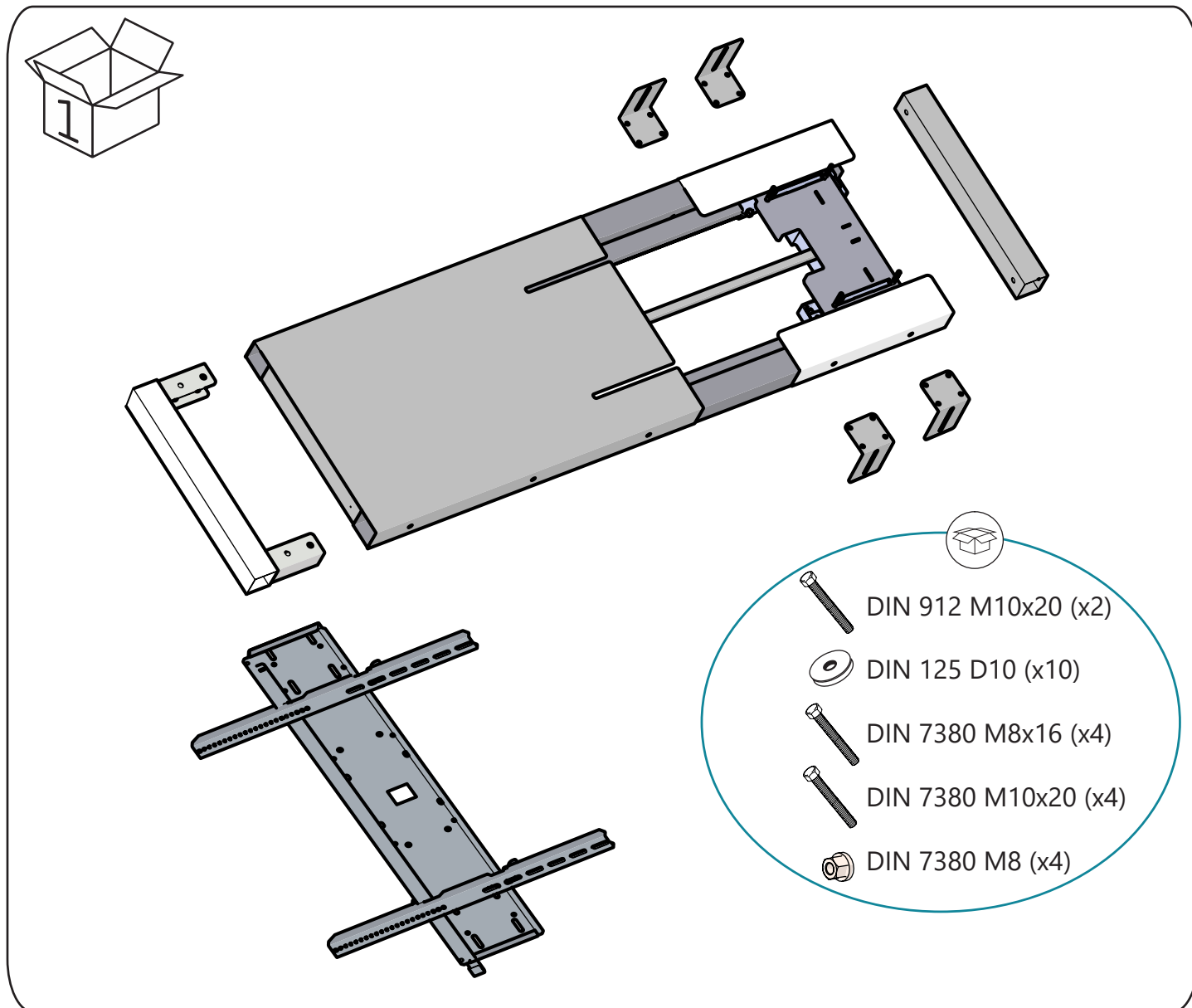

HERRAMIENTAS NECESARIAS/TOOLS NEEDED/ATTREZZI NECESSARI/TARPEELLISET TYÖKALUT/OUTILS NÉCESSAIRES:

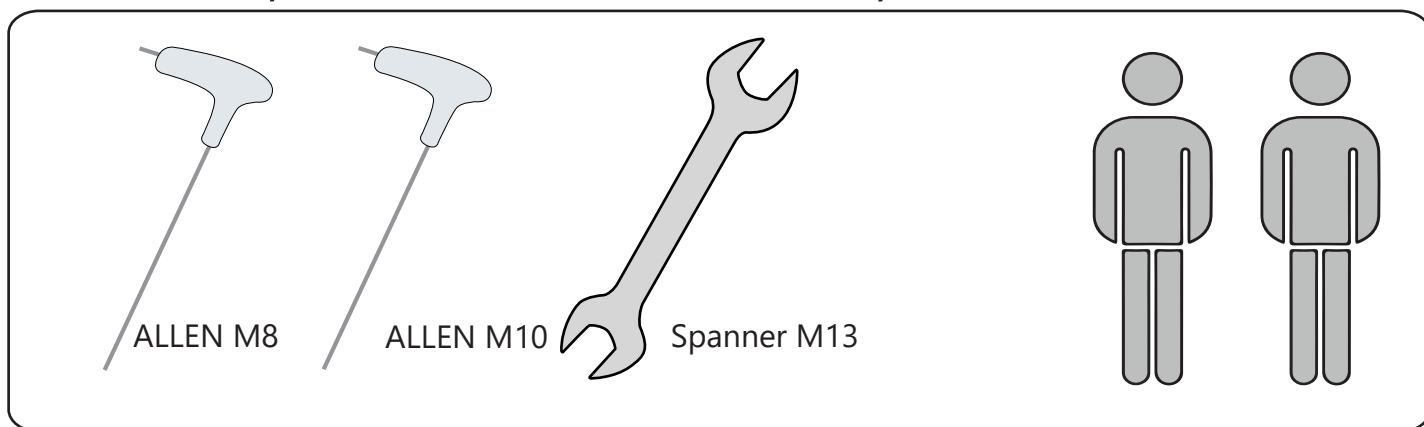

1

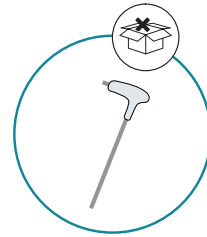
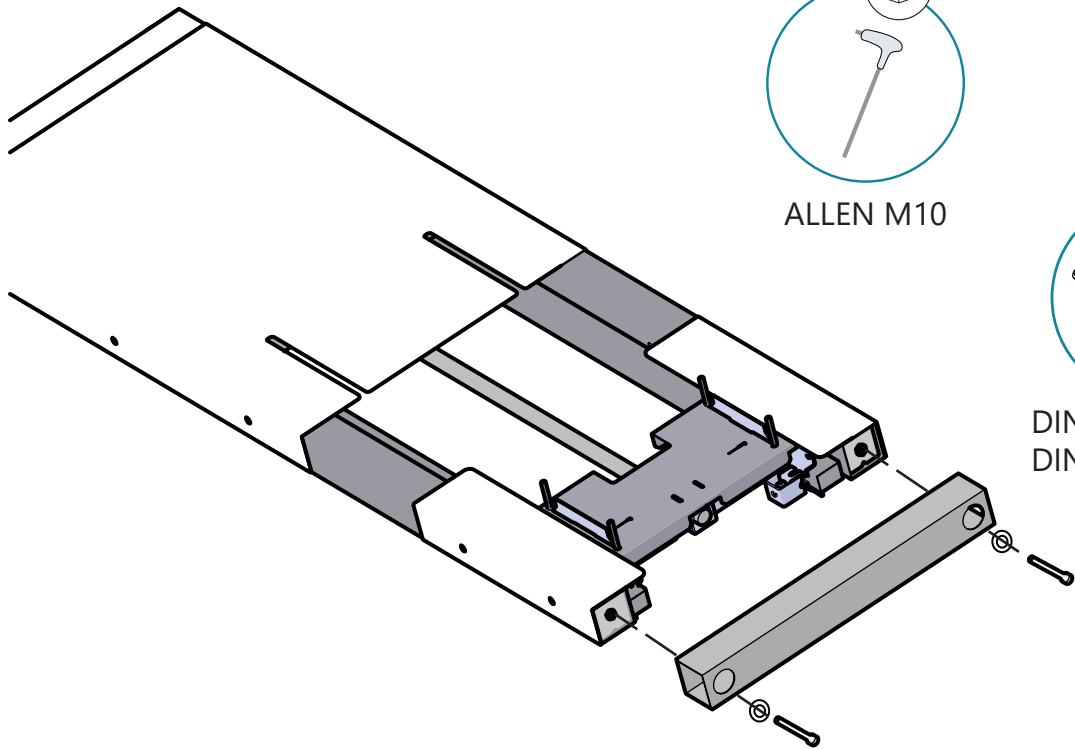

ALLEN M10

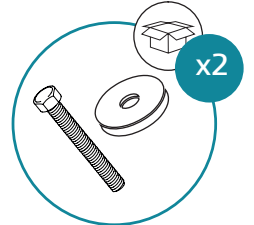

DIN 912 M10x20(x2)
DIN 125 D/10

2

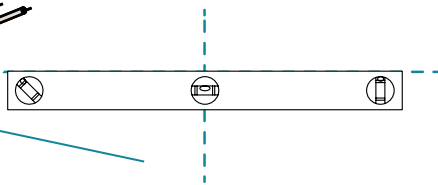
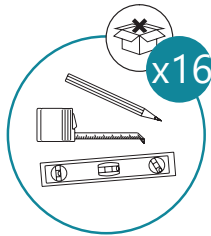
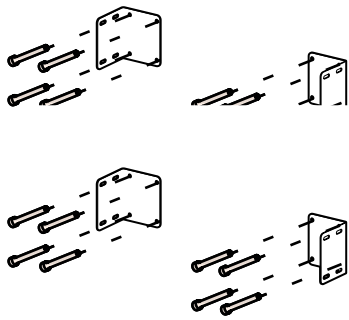

3

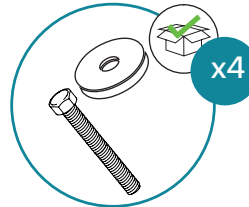

DIN 7380 M10x20 (x4)
DIN 125 D/10

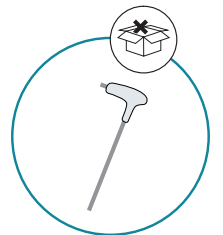

ALLEN M8

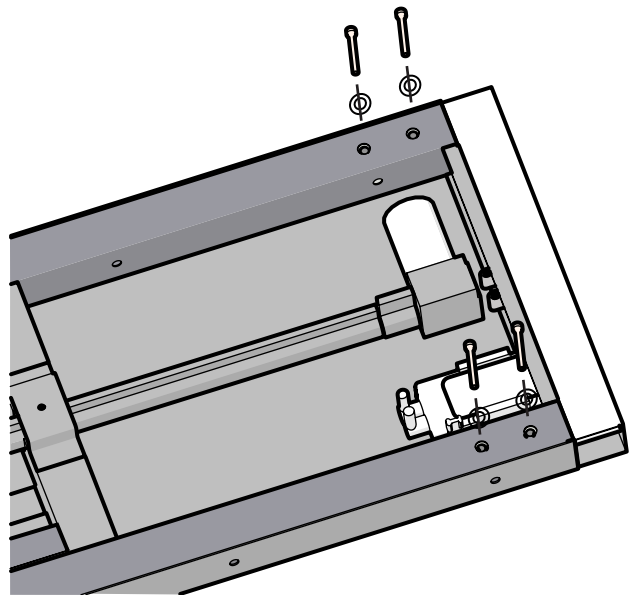

4

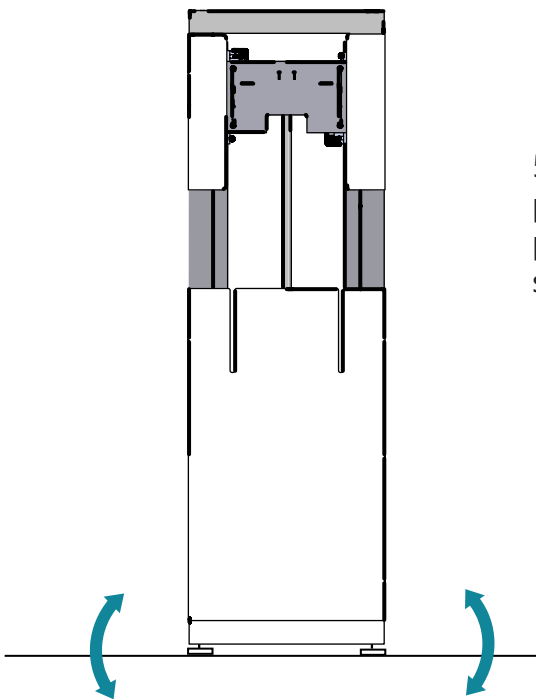

5

5 Different positions, 2 pieces per side

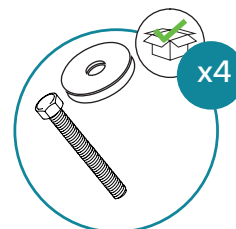
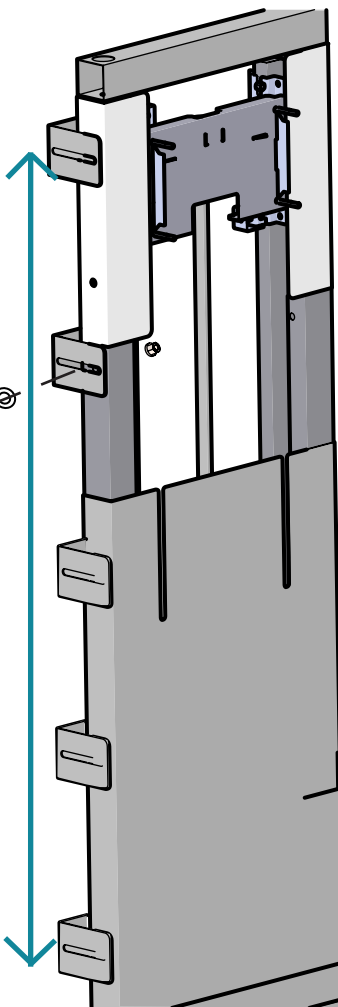

DIN 7380 M8x16 (x4)
DIN 125 D/10

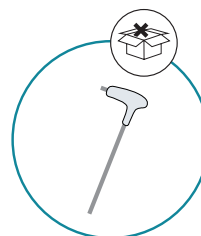

ALLEN M8

6

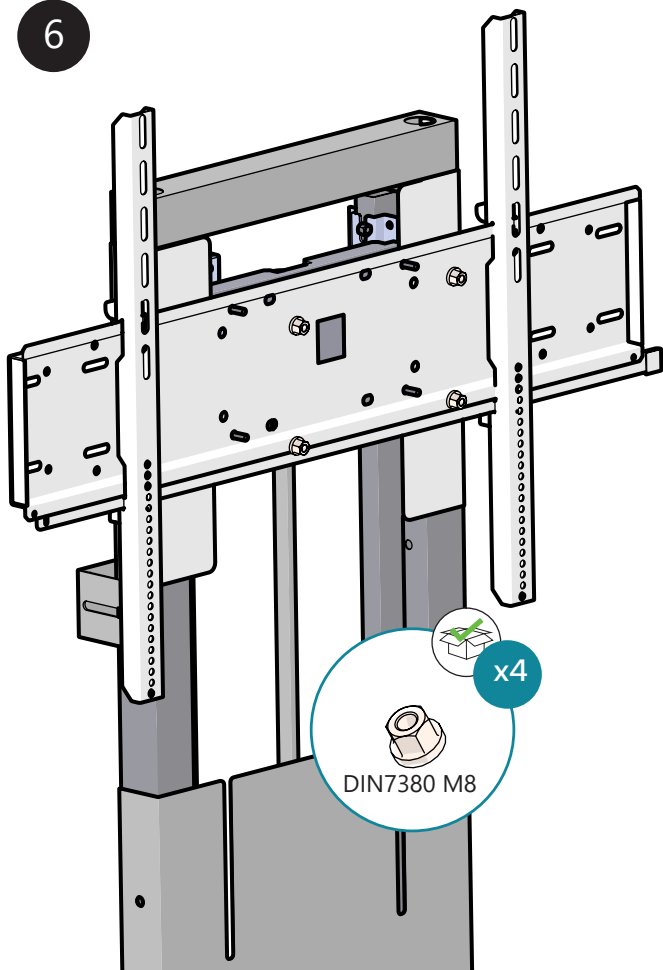

DIN7380 M8

7

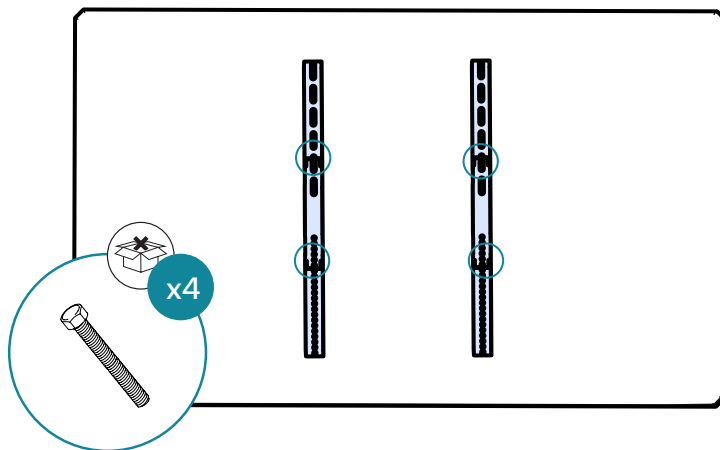

x4

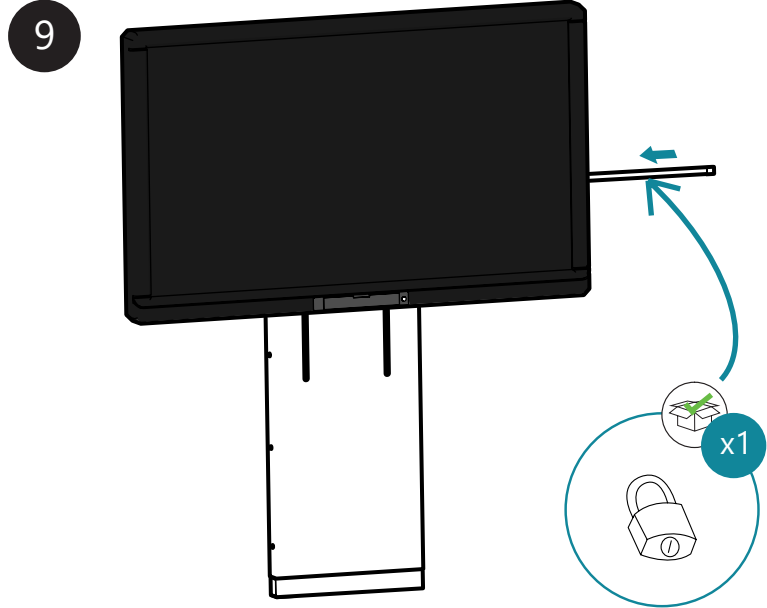

DIAGRAMA ELÉCTRICO DEL MOTOR / ELECTRICAL DIAGRAM OF THE LIFTING SYSTEM / DIAGRAMMA DELL'IMPIANTO ELETTRICO DI SOLLEVAMENTO / NOSTOJÄRJESTELMÄN TEKNINEN KAAVA / SCHÉMA ÉLÉCTRIQUE DU SYSTÈME DE REHAUSSE.

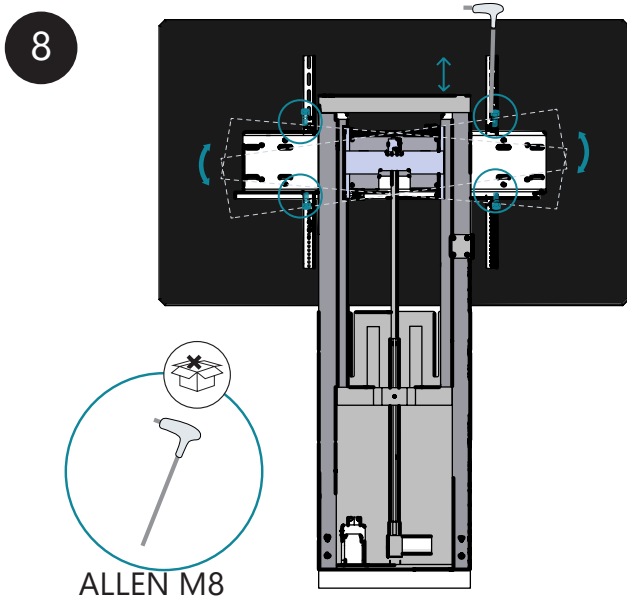
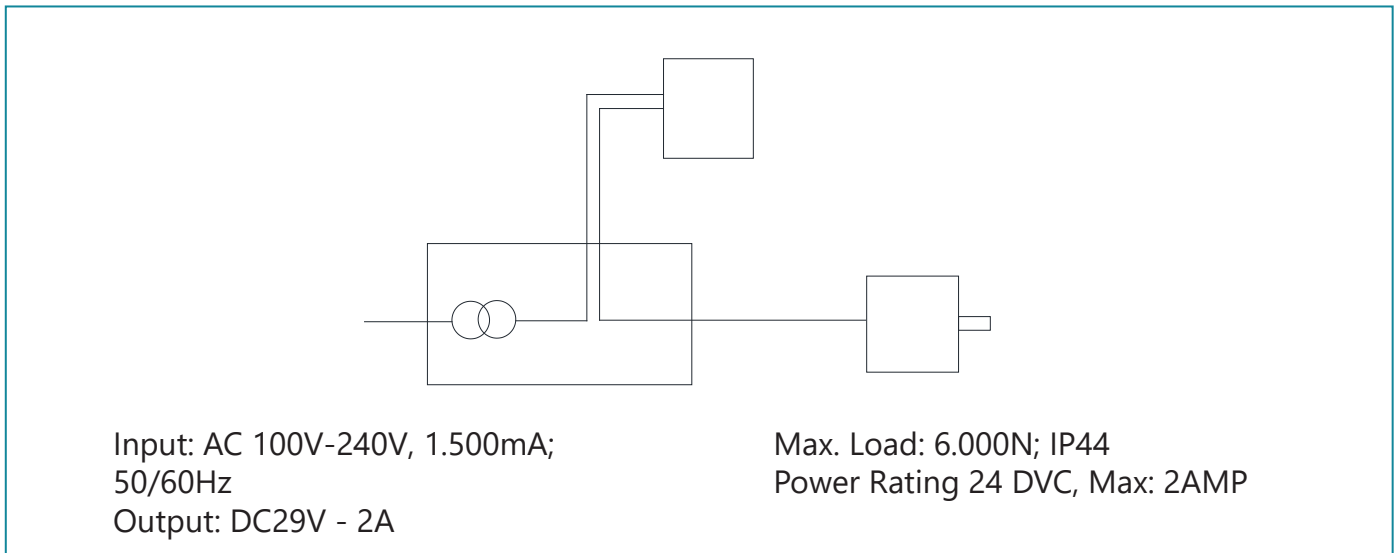

DIMASA
Education, Corporate & Rental Mounts

BARCELONA:
Pasatje Santa Rosa nº8-10, 08105 Sant Fost de Campcentelles (Barcelona) Tel: +34934620604 / +34916169688
MADRID:
c/ Parque Ferial nº 11, Pol. Ind. Urtinsa II, 28923 Alcorcón (Madrid)
Tel.: +34 91 616 96 88